

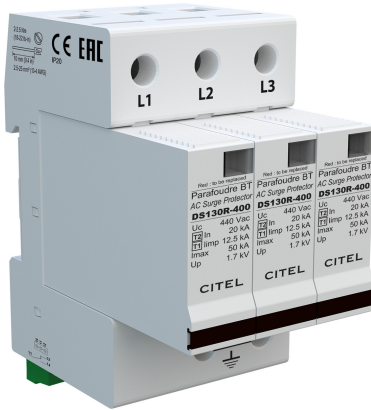

CITEL

Type 1+2 AC surge protector

DS133RS-400



- › Discover our latest innovation : the [DAC1-13S-30-440](#)
- › Type 1 + 2 AC multipolar surge protector
- › In : 20 kA
- › Iimp total : 37.5 kA
- › Pluggable module for each phase
- › Remote signaling
- › EN 61643-11, IEC 61643-11 compliance

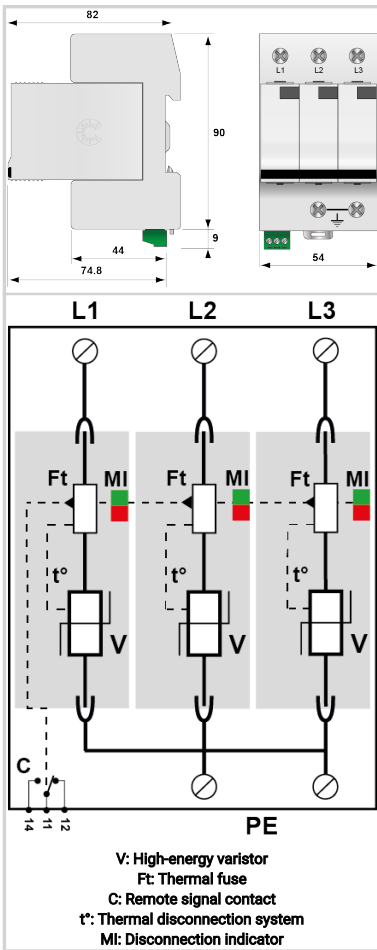

Electrical Characteristics

SPD type	IEC	1+2
Network		480 V 3-phase
AC system		IT
Nominal line voltage	Un	400 Vac
Max. AC operating voltage	Uc	440 Vac
Temporary Over Voltage (TOV) Characteristics - 5 sec. Without disconnection	UT	580 Vac withstand
Temporary Over Voltage (TOV) Characteristics - 120 mn Without disconnection or with safety disconnection	UT	770 Vac disconnection
Follow current	If	None
Nominal discharge current 15 x 8/20 μ s impulses	In	20 kA
Max. discharge current max. withstand @ 8/20 μ s by pole	I _{max}	50 kA
Impulse current by pole max. withstand 10/350 μ s by pole	I _{imp}	12.5 kA
Total lightning current max. total withstand @ 10/350 μ s	I _{total}	37.5 kA
Withstand on overvoltages IEEE C62.41.1		20 kV
Specific energy by pole max. withstand 10/350 μ s	W/R	40 kJ/ohm
Connection mode(s)		L/PE
Protection mode(s)		Common mode
Protection level L/PE @ In (8/20 μ s)	Up L/PE	1.7 kV
Admissible short-circuit current	I _{scrr}	25 000 A

Mechanical Characteristics

Technology		MOV
SPD configuration		3-phase
Connection to Network		By screw terminals: 2.5-25mm ² / by bus
Format		Plug-in modular box
Mounting		Symmetrical rail 35 mm (EN 60715)
Housing material		Thermoplastic UL94 V-0
Operating temperature	Tu	-40/+85°C
Protection rating		IP20
Failsafe mode		Disconnection from AC network
Disconnection indicator		1 mechanical indicator by pole
Spare module(s)		DSM130R-400
Remote signaling of disconnection		Output on changeover contact
Dimensions		See diagram

Disconnectors

Thermal disconnector		Internal
Installation ground fault breaker		Type 'S' or delayed
Back-up protection device		Fuses Type gG - 125 A

Standards

Standards compliance		IEC 61643-11 / EN 61643-11 / UL1449 ed.5
Certification		

Part number

571413

