



# CITEL

## Type 1+2+3 AC surge protector - 3-phase+N

### DAC1-13VGS-31-150



- Type 1 + 2 + 3 AC surge protector
- VG Technology
- In : 20 kA
- Iimp : 12,5 kA on 10/350µs impulse
- No leakage current
- Pluggable module for each phase
- Remote signaling
- Optimized to TOV
- EN 61643-11, IEC 61643-11 and UL1449 ed.5 compliance
- Certified EN 61643-11 and IEC 61643-11

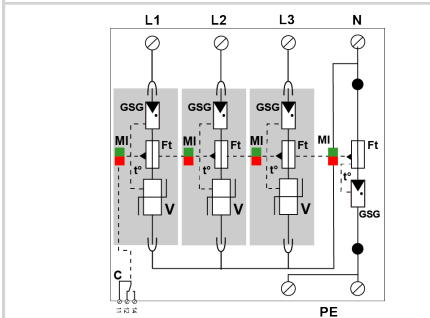
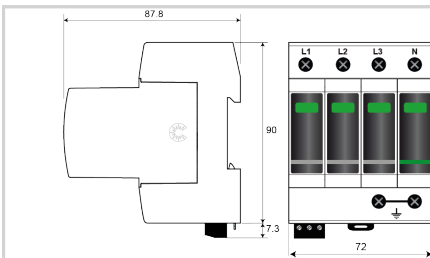

**V:** High-energy varistor  
**GSG:** Specific gas tube  
**Ft:** Thermal fuse  
**C:** Remote signaling contact  
**t\*:** Thermal disconnection system  
**MI:** Disconnection indicator

#### Electrical Characteristics

SPD type	IEC	1+2+3
Network		120/208 V 3-phase+N
AC system		TT-TNS
Max. AC operating voltage	Uc	150 Vac
Temporary Over Voltage (TOV) Characteristics - 5 sec. <i>Without disconnection</i>	UT	180 Vac withstand
Temporary Over Voltage (TOV) Characteristics - 120 mn <i>Without disconnection or with safety disconnection</i>	UT	230 Vac withstand
Temporary Over Voltage N/PE (TOV HT) <i>Without disconnection or with safety disconnection</i>	UT	1200 V/300A/200 ms withstand
Residual Current <i>Leakage current to Ground</i>	Ipe	None
Follow current	If	None
Nominal discharge current <i>15 x 8/20 µs impulses</i>	In	20 kA
Max. discharge current <i>max. withstand @ 8/20 µs by pole</i>	I <sub>max</sub>	50 kA
Total Maximum discharge current <i>max. total withstand @ 8/20 µs</i>	I <sub>max Total</sub>	100 kA
Impulse current by pole <i>max. withstand 10/350µs by pole</i>	I <sub>imp</sub>	12.5 kA
Impulse current N/PE <i>max. withstand 10/350µs</i>	I <sub>imp N /PE</sub>	50 kA
Total lightning current <i>max. total withstand @ 10/350µs</i>	I <sub>total</sub>	50 kA
Withstand on Combination waveform IEC 61643-11 <i>Class III test: 1.2/50µs - 8/20µs</i>	Uoc	6 kV
Specific energy by pole <i>max. withstand 10/350 µs</i>	W/R	40 kJ/ohm
Protection mode(s)		L/N and N/PE
Protection level <i>@ In (8/20µs) and @ 6 kV (1,2/50 µs)</i>	Up L/N	1.5 kV
Protection level N/PE <i>@ In (8/20µs) and @ 6 kV (1,2/50 µs)</i>	Up N/PE	1.5 kV
Residual voltage L/N at 5 kA <i>@ 5 kA (8/20µs)</i>	Up-5kA	0.4 kV
Protection level N/PE at 5 kA <i>@ 5 kA (8/20µs)</i>	Up-5kA	0.4 kV
Admissible short-circuit current	I <sub>scrr</sub>	50 000 A

#### Mechanical Characteristics

Technology		VG Technology (MOV+GSG)
SPD configuration		3-phase+Neutral
Connection to Network		By screw terminals: 2.5-25mm <sup>2</sup> (35mm <sup>2</sup> rigid)
Format		Plug-in modular box
Mounting		Symmetrical rail 35 mm (EN 60715)
Housing material		Thermoplastic UL94 V-0
Operating temperature	Tu	-40/+85°C
Protection rating		IP20
Failsafe mode		Disconnection from AC network
Disconnection indicator		1 mechanical indicator by pole - Red/Green
Spare module(s)		MDAC1-13VG-150 + MDAC1-50G-xxx
Remote signaling of disconnection		output on changeover contact
Wiring for remote signaling		1.5 mm <sup>2</sup> max.
Max. Voltage/Current for remote signaling		250 V / 0.5 A (AC) / 30 V / 3 A (DC)
Dimensions		See diagram - 4TE (EN43880)

#### Disconnectors

Thermal disconnector		Internal
----------------------	--	----------



# CITEL

## Type 1+2+3 AC surge protector - 3-phase+N

### DAC1-13VGS-31-150

Installation ground fault breaker		Type 'S' or delayed
Back-up protection device		Fuse assembly: SFD1-13S-40 /or 125 A min. - 315 A max. - Fuses Type gG
<b>Standards</b>		
Standards compliance		IEC 61643-11 / EN 61643-11 / UL1449 ed.5
Certification		KEMA
<b>Part number</b>		
<b>821730144</b>		

