

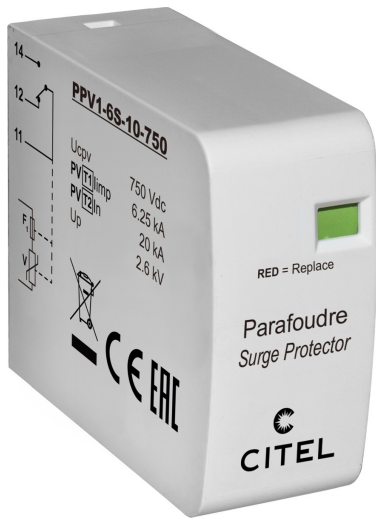

CITEL

Type 1+2 PV Surge Protector for PCB mounting

PPV1-6S-10-750



- Type 1+2 surge protector for Photovoltaic
- PCB mounting
- Iimp : 6.25 kA (10/350 μs)
- Remote signaling
- EN 50539-11 and IEC 61643-31 compliance*

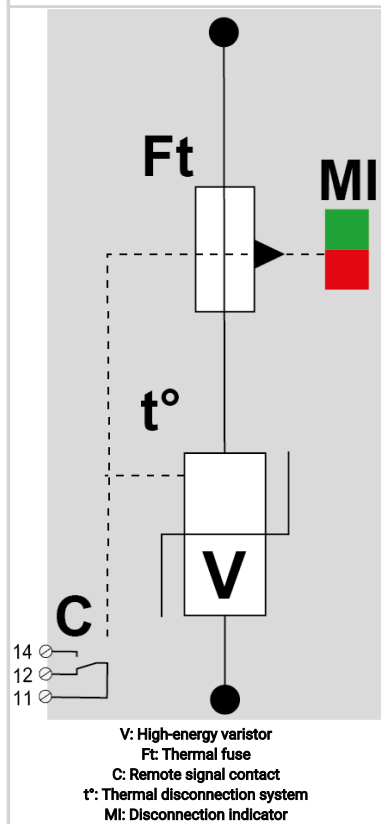
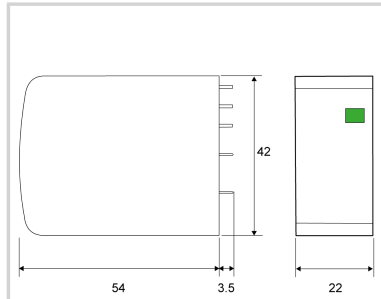

Electrical Characteristics		
SPD type	IEC	1+2
Max. PV operating voltage	Ucpv	750 Vdc
Max. PV operating voltage (star mounting)	Ucpv	1500 Vdc
PV Permanent Operating current	Icpv	< 0.1 mA
Current consumption at Ucpv		
Nominal discharge current	In	20 kA
15 x 8/20 μs impulses		
Impulse current by pole	Iimp	6.25 kA
max. withstand 10/350μs by pole		
Current withstand short circuit PV	Iscpv	15 000 A
Protection level	Up	2.6 kV
@ In (8/20μs)		
Protection level (star mounting)	Up	5.2 kV
(+/-) / (+/PE or -/PE) @ In (8/20μs)		
Mechanical Characteristics		
Connection to Network		Through soldering pins
Mounting		On Printed Circuit Board
Housing material		Thermoplastic UL94 V-0
Operating temperature	Tu	-40/+85°C
Protection rating		IP20
Disconnection indicator		Mechanical indicator
Remote signaling of disconnection		Output on changeover contact
Dimensions		See diagram
Disconnectors		
Thermal disconnector		Internal
Back-up protection device		Without
Standards		
Standards compliance		IEC 61643-31 / EN 50539-11 *The standard cover devices. PPV /PAC series are components. Compliant when combined is an assembly.
Part number		
8723205		

