



# CITEL

### CL-DSL



- Surge protection for telecommunication applications
- Protection of VDSL2, VDSL, DSL, ISDN and analog terminals
- Extended frequency range up to 400 MHz
- Wall mounting

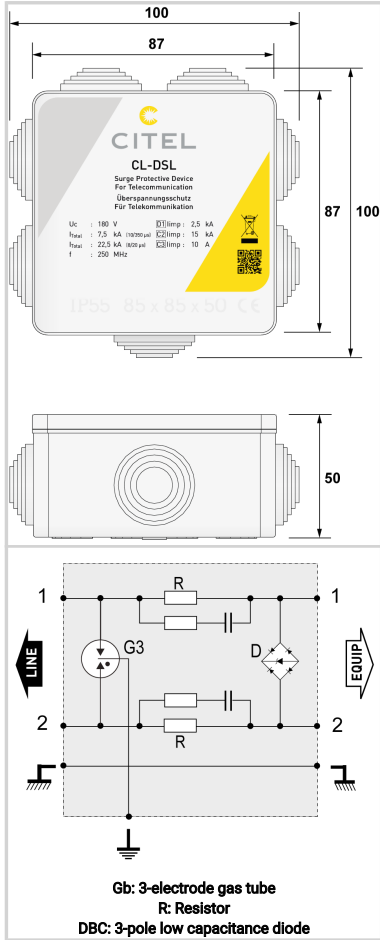

Electrical Characteristics		
Network		RTC, ADSL2, VDSL2
Nominal line voltage	Un	180 V
Max. DC operating voltage	Uc	180 Vdc
Max. frequency	f max.	400 MHz
Insertion loss		< 3 dB
Max. load current @25°C	IL	750 mA
Nominal discharge current C2 Category	In	15 kA
Protection Level C3 (10/1000µs), 300 applications@10 A, Y-C (Line/Earth)	Up	< 280 V
Impulse current 2 x 10/350µs Test - D1 Category	Iimp	2.5 kA
Mechanical Characteristics		
Technology		GDT+TVS diode
SPD configuration		1 pair
Connection to Network		Spring terminal: cross section 0.5-2.5mm <sup>2</sup>
Format		Wall mounting box
Mounting		Wall mounting by screws (not supplied)
Housing material		Thermoplastic UL94 V-0
Operating temperature	Tu	-40/+85°C
Protection rating		IP55
Failsafe mode		Short-circuit - transmission cut-off - fault mode 2
Dimensions		See diagram
Standards		
Standards compliance		IEC 61643-21 / EN 61643-21
Part number		
<b>6400066</b>		

