



CITEL

Type 2 AC surge protector - Re-inforced - pluggable

DAC80S-40-440



- Re-inforced Type 2 AC surge protector
- In: 40 kA
- Imax: 80 kA
- Pluggable module for each phase
- Remote signaling
- EN 61643-11, IEC 61643-11 certified
- UL1449 ed.5 compliance

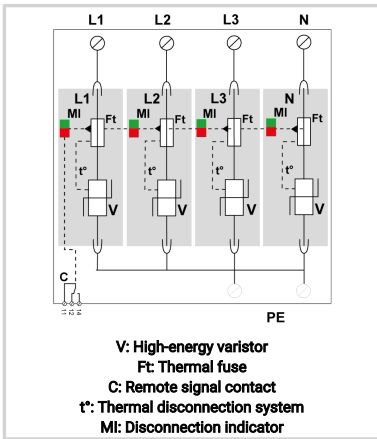

Electrical Characteristics		
SPD type	IEC	2
Network		480 V 3-phase
AC system		IT
Max. AC operating voltage	Uc	440 Vac
Temporary Over Voltage (TOV) Characteristics - 5 sec. Without disconnection	UT	580 Vac withstand
Temporary Over Voltage (TOV) Characteristics - 120 mn Without disconnection or with safety disconnection	UT	770 Vac disconnection
Residual Current Leakage current to Ground	Ipe	< 1 mA
Follow current	If	None
Nominal discharge current 15 x 8/20 μs impulses	In	40 kA
Max. discharge current max. withstand @ 8/20 μs by pole	Imax	80 kA
Protection mode(s)		L/PE and N/PE
Protection level N/PE @ In (8/20μs)	Up N/PE	2 kV
Protection level L/PE @ In (8/20μs)	Up L/PE	2 kV
Admissible short-circuit current	Iscsr	50 000 A
Mechanical Characteristics		
Technology		MOV
Connection to Network		By screw terminals: 2.5-25mm ² (35mm ² rigid)
Format		Plug-in modular box
Mounting		Symmetrical rail 35 mm (EN 60715)
Housing material		Thermoplastic UL94 V-0
Operating temperature	Tu	-40/+85°C
Protection rating		IP20
Failsafe mode		Disconnection from AC network
Disconnection indicator		1 mechanical indicator by pole - Red/Green
Spare module(s)		MDAC80-440
Remote signaling of disconnection		Output on changeover contact
Max. Voltage/Current for remote signaling		250 V / 0.5 A (AC) / 30 V / 3 A (DC)
Dimensions		See diagram - 4TE (EN43880)
Disconnectors		
Thermal disconnector		Internal
Installation ground fault breaker		Type 'S' or delayed
Back-up protection device		Fuses Type gG - 125 A
Standards		
Standards compliance		IEC 61643-11 / EN 61643-11 / UL1449 ed.5
Certification		KEMA
Part number		
821210424		

