



# AK1.K3x16.K3x16.50VGS-11-275

# CITEL



- Universal small housing for individual cable entry with consideration of practical cross-sections
- Internal terminal design allows spur or V-wiring (series)
- Suitable for TN-TT mains types
- Integrated DAC50VGS-11-275
- Type 2+3 combined arrester based on a gas-filled spark gap
- Discharge capacity per pole:  $I_n=20kA (8/20\mu s)$ ;  $I_{max}=50kA (8/20\mu s)$
- Pluggable protection modules
- Remote signalling as standard

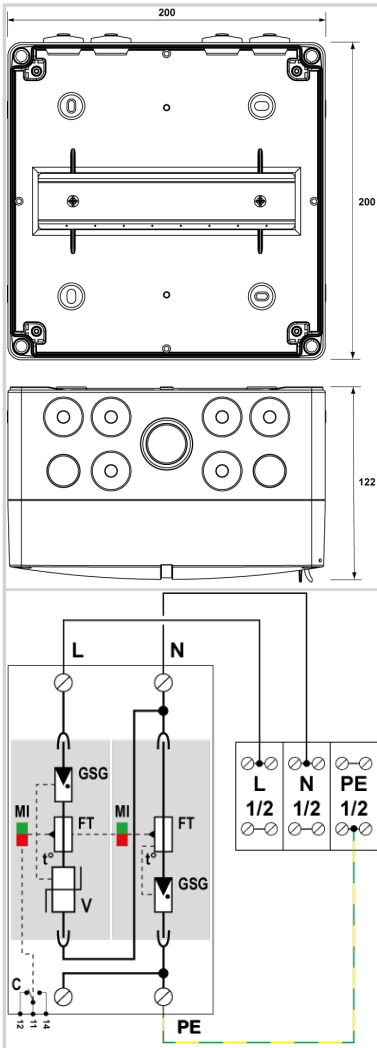

Electrical Characteristics		
SPD type	IEC	2+3
Nominal line voltage	Un	230/400 Vac
Max. AC operating voltage	Uc	275 Vac
Max. load current <i>if series connection</i>	IL	bis 85 A (Verlegeart beachten)
Surge protection device		DAC50VGS-11-275 (internally pre-wired)
Nominal frequency	fn	0-100 Hz
Mechanical Characteristics		
Housing material		Thermoplastic UL94 V-0
Protection rating		IP65
Dimensions		See diagram - 3 TE (EN43880)
Entrance		Screw terminals max. 16mm <sup>2</sup> (re or rm)
Outgoing		Screw terminals max. 16mm <sup>2</sup> (re or rm)
Earth connection terminal		Screw terminals max. 16mm <sup>2</sup> (re or rm)
Ambient temperature		-25°C bis +40°C / 24h up to max. 35°C
Cable gland		Double diaphragm connector Cable glands M20 / M25 / M32
Humidity		Relative humidity (25°C) 5% to 95% / Max. relative air humidity (40°C) 50%.
Shock resistance		IK 07
Standards		
Standards compliance		IEC 61643-11
Part number		
159143		

