

# String combiner box (SCB) CiPlug1 for 1 MPP tracker



Example:  
CiPlug1-51VG-12



- SCB for 1 MPP tracker
- Integrated surge protection
- IP65 housing
- Premassembled connection cables with MC4-plugs
- Other solutions available on request

## CiPlug1- 51VG-12

«61VG-1» DS60VGPV-1000G/51  
 «51VG-12» DS50VGPVS-1000G/12KT1  
 «51VG-1» DS50VGPVS-1000G/51  
 «51-1» DS50PVS-1000G/51  
 «VG» VG-Technology  
 «1» number of SPD

## Dimension and diagram

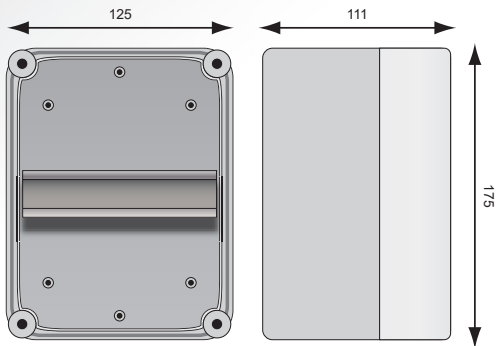

CiPlug1 with VG-Technology

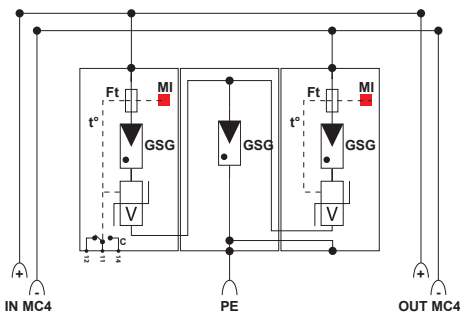

CiPlug1 with MOV-Technology

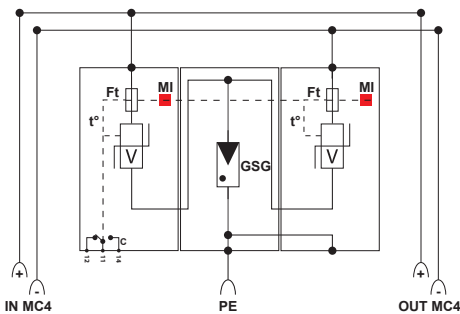

GSG : Gas-filled spark gap  
 V : High energy MOV  
 Ft : Thermal fuse  
 t° : Thermal disconnection mechanism  
 C : Contact for remote signal  
 MI : Disconnection indicator

## Technical data

Electrical characteristics		CiPlug1	
Nominal voltage	Un	1000 Vdc	
Rated insulation voltage	Ui	1000 Vdc	
Rated current	InA	20 A	
Rated phase current	InC	20 A	
Connection options			
Input / per MPPT		MC4 plug 1x 6mm <sup>2</sup> with 15cm connection cable	
Output / per MPPT		MC4 plug 1x 6mm <sup>2</sup> with 120cm connection cable	
Ground connection terminal		Screw terminal 2.5-25 mm <sup>2</sup> [35 mm <sup>2</sup> ]	
Cable gland		1x M24 (Ø 6-12mm) PE	
Other characteristics			
Housing material		UV and ozone resistant, glass fibre reinforced Polycarbonate with transparent lid	
Dimensions		BxHxT (mm): 125 x 175 x 111	
Ambient temperatures		Indoor: -5°C to max. +40°C (+35°C 24h average value) Outdoor: -25°C to max. +40°C (+35°C 24h average value)	
Humidity		Indoor: max. 50% at +40°C, max. 90% at 20°C (non condensing) Outdoor: 95% at +25°C. (non condensing)	
Protection rating		IP 65	
Protection class		II	
Impact resistance		IK 8	
Pressure compensation element		Integrated	
Components			
DC disconnection		none	
Fuse holder		none	
Surge protection			
Standard compliance		DIN EN 50539-11	
Technology		VG-Technology	MOV
Type of surge protection		Combined arrester Type 1+2	SPD Type 2
Surge protection device		61VG-1 51VG-12	51VG-1 51-1
Article number			
		158551	158552 158553 158554



### Standard definition InA

The rated current of the switchgear combination InA is the total current which the main busbar can distribute in the respective structure of the combination without exceeding the temperature limits according to DIN EN 61439-1 Tab. 6 9.2!  
 The current InA is seen as the maximum current that the combination can distribute across its outgoing feeders at 100% duty cycle (ED).

### Standard definition InC

The rated current of a circuit is the value of the current that can be carried by that circuit under normal operating conditions when operated alone. It must be possible to conduct it without the excess temperature of the individual components exceeding the limits specified in DIN EN 61439-1 9.2.