



DAC40CS-31

# DAC40CS SERIES

- Compact 3-phase Type 2
- Common/Differential mode
- Remote signaling contact
- EN 61643-11, IEC 61643-11 certified
- UL1449 ed.5 compliance



DAC40CS-xx-xxx

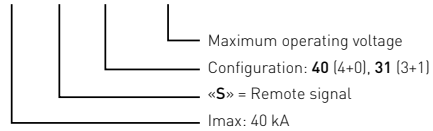

## Characteristics

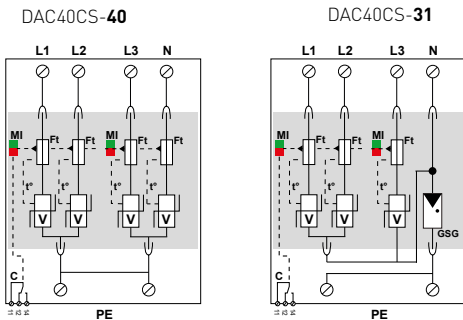
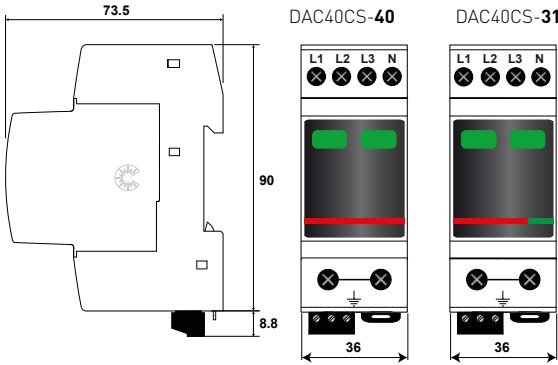

V : High energy varistor  
 GSG : Specific GDT  
 Ft : Thermal fuse  
 C : Contact remote signaling  
 t<sup>°</sup> : Thermal disconnection system  
 MI : Disconnection indicator

CITEL Model		DAC40CS-40-440	DAC40CS-31-275	DAC40CS-31-150
Description		Compact 3-phase+N Type 2 surge protector - Pluggable		
Network		230/400 V 3-phase	230/400 V 3-phase	120/208 V 3-phase
Protection mode		L/PE and N/PE	L/N and N/PE	L/N and N/PE
AC system		IT	TT-TN	TT-TN
Max. AC operating voltage	Uc	440 Vac	275 Vac	150 Vac
Temporary Over Voltage (TOV)	UT	580 Vac	335 Vac	180 Vac
Characteristic - 5 sec.		withstand	withstand	withstand
Temporary Over Voltage (TOV)	UT	770 Vac	440 Vac	230 Vac
Characteristic - 120mn		disconnection	disconnection	disconnection
Temporary Over Voltage N/PE (TOV HT)	UT	-	1200 V/300A/200 ms withstand	1200 V/300A/200 ms withstand
Residual current - Leakage current at Uc	Ipe	< 1 mA	None	None
Follow current	If	None	None	None
Nominal discharge current 15 x 8/20 μs impulses	In	20 kA	20 kA	20 kA
Max. discharge current max. withstand @ 8/20 μs by pole	Imax	40 kA	40 kA	40 kA
Total discharge current @8/20μs	Itotal	160 kA	40 kA	40 kA
Protection level @In (8/20μs)	Up L/N	-	1.25 kV	0.9 kV
	Up N/PE	1.8 kV	1.5 kV	1.5 kV
	Up L/PE	1.8 kV	-	-
Admissible short-circuit current	Iscrr	10000 A	10000 A	10000 A
<b>Associated disconnectors</b>				
Thermal disconnector		internal		
Associated fuses		50 A min. - 125 A max. - Type gG		
Existing upstream ground fault breaker (if any)		Type "S" or delayed		
<b>Mechanical characteristics</b>				
Dimensions		see diagram, 2 TE (DIN43880)		
Connection to Network		by screw terminals: L/N = 1.5-10mm <sup>2</sup> [16 mm <sup>2</sup> ] or PE = 2.5-25mm <sup>2</sup> [35 mm <sup>2</sup> rigid]		
Failsafe mode		Disconnection from network		
Disconnection indicator		2 mechanical indicators, Green/Red		
Max. voltage/current for remote signaling		250 V/0.5 A (AC) / 30 V/3 A (DC)		
Wiring for remote signaling		Max. 1.5 mm <sup>2</sup>		
Mounting		Symmetrical rail 35 mm (EN60715)		
Operating temperature		-40/+85°C		
Protection rating		IP20		
Housing material		Thermoplastic UL94 V-0		
Spare unit		MDAC40C-40-440	MDAC40C-31-275	MDAC40C-31-150
<b>Standards</b>				
Certification		KEMA		
Compliance		IEC 61643-11 / EN 61643-11 / UL1449 ed.5		
<b>Part number</b>				
		821510422	821520222	821520122