

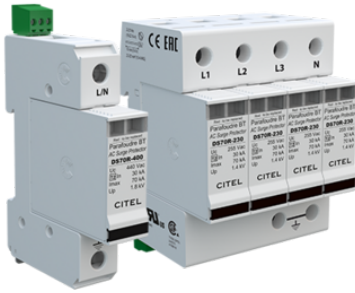

## Type 2 AC surge protector - 3-phase

# CITEL

## DS73RS-230



- Re-inforced Type 2 AC Multipolar surge protector
- In: 30 kA
- I<sub>max</sub> total: 210 kA
- Pluggable module by phase
- Remote signaling
- IEC 61643-11, EN 61643-11 compliance
- UL1449 ed.5 approved

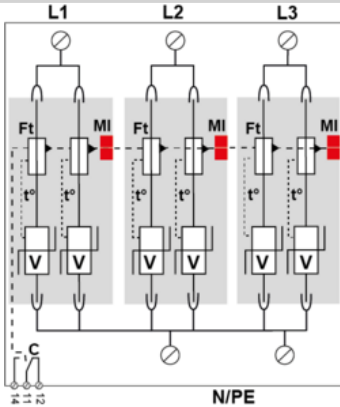

V: High-energy varistor  
 Ft: Thermal fuse  
 C: Remote signal contact  
 t\*: Thermal disconnection system  
 MI: Disconnection indicator

Electrical Characteristics		
SPD type		2
Network		230/400 V 3-phase
AC system		TNC
Nominal line voltage	U <sub>n</sub>	230 Vac
Max. AC operating voltage	U <sub>c</sub>	255 Vac
Temporary Over Voltage (TOV) Characteristics - 5 sec. Without disconnection	UT	335 Vac withstand
Temporary Over Voltage (TOV) Characteristics - 120 mn Without disconnection or with safety disconnection	UT	440 Vac disconnection
Residual Current Leakage current to Ground	I <sub>pe</sub>	< 3 mA
Follow current	I <sub>f</sub>	None
Nominal discharge current 15 x 8/20 μs impulses	I <sub>n</sub>	30 kA
Max. discharge current max. withstand @ 8/20 μs by pole	I <sub>max</sub>	70 kA
Total Maximum discharge current max. total withstand @ 8/20 μs	I <sub>max</sub> Total	210 kA
Connection mode(s)		L/PE
Protection mode(s)		Common mode/Differential mode
Residual voltage at 5 kA @ 5 kA (8/20 μs)	U <sub>p-5kA</sub>	0.9 kV
Admissible short-circuit current	I <sub>sc</sub>	25 000 A
Mechanical Characteristics		
Technology		MOV
SPD configuration		3-phase
Connection to Network		By screw terminals: 2.5-25mm <sup>2</sup> / by bus
Format		Plug-in modular box
Mounting		Symmetrical rail 35 mm (EN 60715)
Housing material		Thermoplastic UL94 V-0
Operating temperature	T <sub>u</sub>	-40/+85°C
Protection rating		IP20
Failsafe mode		Disconnection from AC network
Disconnection indicator		2 mechanical indicators by pole
Spare module(s)		DSM70R-230
Remote signaling of disconnection		Output on changeover contact
Dimensions		See diagram
Weight		0.374 kg
Disconnectors		
Thermal disconnector		Internal
Installation ground fault breaker		Type 'S' or delayed
Back-up protection device		100 A min. - 125 A max. - Fuses type gG
Standards		
Standards compliance		IEC 61643-11 / EN 61643-11 / UL1449 ed.5
Certification		UL Recognized
Part number		
491523		

