



Compact Type 2 hard wired surge protector

CITEL

2-port MLPCA1-230L-DL



- Compact type 2+3 surge protector
- For protection class I equipment
- Easy installation due to two-port design
- Status signalling
- Unit defective - disconnection from mains and power circuit disconnection
- Meets IEC 61643-11 and EN 61643-11 standards IEC 61643-21 and EN 61643-21
- Particularly suitable for end circuits e.g. LED lighting with protection of control via DALI

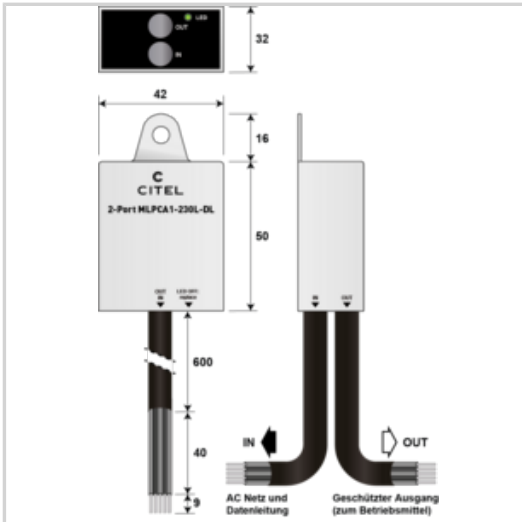

Electrical Characteristics		
SPD type		2+3
Network		220-240V 2-phase + N
AC system		TT-TN
Nominal line voltage	Un	230 V
Max. AC operating voltage	Uc	320 Vac
Max. load current @25°C	IL	5 A
Temporary Over Voltage (TOV) Characteristics - 5 sec. Without disconnection	UT	335 Vac withstand
Temporary Over Voltage (TOV) Characteristics - 120 mn Without disconnection or with safety disconnection	UT	440 Vac disconnection
Follow current	If	None
Nominal discharge current 15 x 8/20 µs impulses	In	5 kA
Max. discharge current max. withstand @ 8/20 µs by pole	Imax	10 kA
Total Maximum discharge current max. total withstand @ 8/20 µs	Imax Total	30 kA
Withstand on Combination waveform IEC 61643-11 Class III test: 1.2/50µs - 8/20µs	Uoc	10 kV
Withstand on overvoltages IEEE C62.41.1		10 kV / 10 kA
Protection mode(s)		Common/Differential mode
Protection level @ In (8/20µs)	Up	1.5 kV
Protection level L/N @ In (8/20µs)	Up L/N	1.5 kV
Protection level L/PE @ In (8/20µs)	Up L/PE	1.5 kV
Admissible short-circuit current	Iscrr	10 000 A
Mechanical Characteristics		
Technology		MOV+GDT
Connection to Network		5-wire rubber hose line 1.5mm ² (in/out)
Mounting		Wall or plate
Housing material		Thermoplastic UL94 V-0
Operating temperature	Tu	-40/+85°C
Protection rating		IP65
Failsafe mode		Disconnection and AC line cut-off
Disconnection indicator		LED green OFF and AC network cut-off
Voltage/operating indicator		Green Led ON
Dimensions		See diagram
Weight		0.152 kg
Disconnectors		
Thermal disconnector		Internal
Installation ground fault breaker		Type 'S' or delayed
Standards		
Standards compliance		IEC 61643-11 / EN 61643-11 / UL1449 ed.5 IEC 61643-21 / N 61643-21 / UL497A
Certification		CE / UKCA
Part number		835283

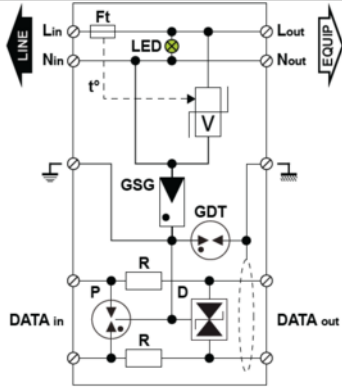

V: Varistor
 GSG: Specific gas tube
 LED: Disconnection indicator
 Ft: Thermal fuse
 t*: Thermal system disconnection

