



CITEL

1-pair monobloc Telecom surge protector

DLC-48D3



- High speed data transmission
- Common mode and differential mode protection
- Data lines, including those isolated from Earth
- Compact DIN rail enclosure, high density protection
- Protection of shield wire
- Location and test categories: D1, C2, C3
- IEC 61643-21 compliance

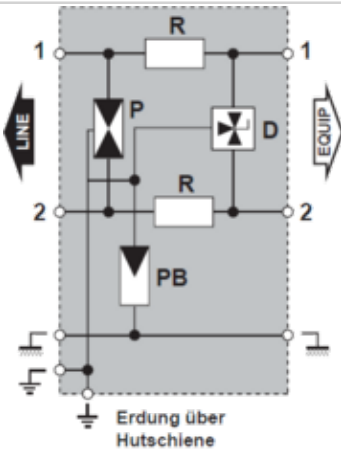
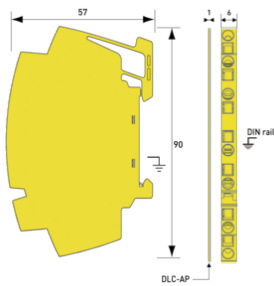

P : 3-poliger Gasableiter
 Pb : 2-poliger Gasableiter
 R : Widerstand oder Spule
 D : Diode

G: 3-electrode gas tube
 Gb: 2-electrode gas tube
 R: Resistor
 D: Clamping diode

Electrical Characteristics	
Network	RNIS-T0, 48 V line
Nominal line voltage	Un 48 V
Max. DC operating voltage	Uc 53 Vdc
Max. frequency	f max. > 3 MHz
Insertion loss	< 1 dB
Max. load current @25°C	IL 300 mA
Max. discharge current max. withstand @ 8/20 µs by pole	I _{max} 10 kA
Line inductance	No
Protection level @ I _n (8/20 µs)	Up L/L 70 V
Impulse current 2 x 10/350µs Test - D1 Category	I _{imp} 2.5 kA
Line/Line Nominal discharge current C2 Category	I _n L/L 5 kA
Nominal Discharge Current, X-C (Line/Earth) 8/20µs Test x 10 - C2 Category	I _n L/PE 5 kA
Line resistance	< 4.7 Ohm
Mechanical Characteristics	
Technology	GDT+Clamping diode
SPD configuration	1-pair+shielded
Connection to Network	By spring - max. cross section 1.5mm ²
Format	DIN box
Mounting	Symmetrical rail 35 mm (EN 60715)
Housing material	Thermoplastic UL94 V-0
Operating temperature	Tu -40/+85°C
Ingress Protection rating	IP20 (NEMA 2)
Failsafe mode	Short-circuit
Disconnection indicator	Transmission interrupt - default mode 2
Dimensions	See diagram
Weight	0.029 kg
Standards	
Standards compliance	IEC 61643-21 / EN 61643-21 / UL497B
Certification	UL 497B
Part number	
641104	

